

Corr-Vac® Mark III



MODIFIED ATMOSPHERE PACKAGING (M.A.P.), sometimes called *Controlled Vacuum Packaged*, is at the heart of everything M-Tek stands for. We preserve and protect and extend the shelf life of your products. Whether it is individual bags, lined cases, bulk-bin, totes, Gaylords, barrel, or super-sacks, M-Tek has a proven solution.

Two hand controls, bag stretchers, and casters as shown are optional. Conveyor shown is for display purposes only.

Features and Options

- 100% stainless steel and FSMA, FDA, & USDA compliant. Optional 3A dairy-grade
- Always ready for wash-down as we build-to IP69 specifications assuring IP67 compliance
- Seal bars available include either 30, 54, and 62-inch lengths
- Vacuum pump or optional liquid-ring and venturi
- Hot-bar or impulse sealing
- Bag-stretcher option to insure wrinkle free bags
- One or optional two hand controls
- Flexible probes reduces damage and extends life
- A variety of language options on our simple to understand controller
- Floor mount, optional casters, or unit can hang over conveyor.

Applications

- Vacuum and gas flush cases - extends shelf life of proteins
- Vacuum followed by dual gas flush mix extends shelf life and product color of red meats
- Gas flush any product that degrades in atmosphere
- Multi-gas flush totes or super-sacks of organic products assuring insects and larvae are asphyxiated
- Poultry, beef & pork, prepared meat, cheese, fish, nuts, powders, organic, industrial



Com-vac MARK III

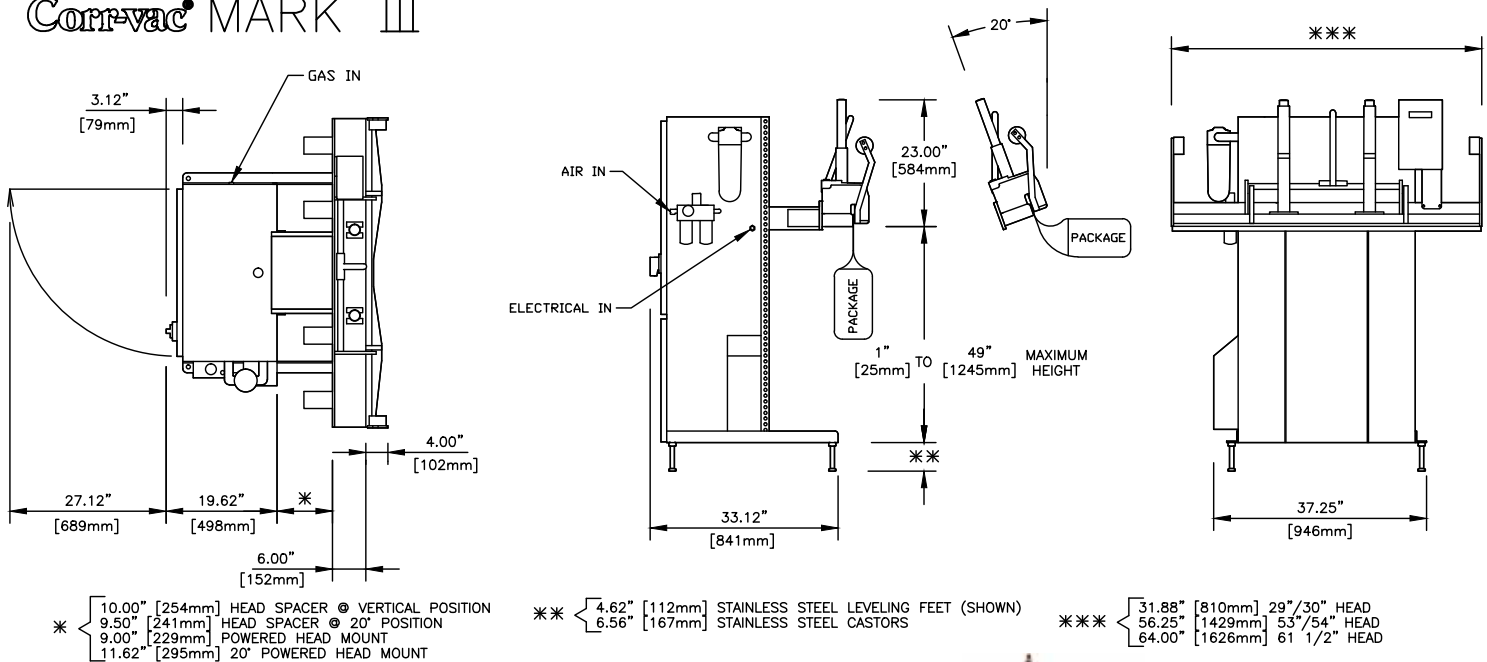

VFFS



Top Load



Bulk Bin Rollaround



Bulk Bin Suspended



HSP

